

GREEN POWER IVECO DIESEL ENGINE

1500 RPM	Type GP80F
----------	------------

The Engine with integrated water cooling

Engine: NEF N45SM3

Technical description

- Optimized cast iron cylinder block with optimum distribution of forces
- Piston cooling for low piston temperature and reduced ring temperature
- Powerful but 4.5 litre naturally aspirated 4 cylinder compact Engine
- Crankshaft hardened bearing surfaces and fillets for moderate on main and big end bearings
- Keystone top compression rings for long service life
- Replaceable valve guides and valve seats
- Thermostatically controlled system with gear driven circulation pump
- Lift eyelets
- Flywheel housing SAE 3
- Flywheel for flexible coupling and friction clutch
- Front engine mounting brackets

Benefits

- Low noise emission, cost savings as no noise attenuation measures are required
- Long service intervals: 1000 hour oil change intervals and low fuel consumption bring savings in Operating costs
- Low installation costs
- Excellent load takeover characteristics ensure prompt power supply
- Combined oil cooling and lubrication prevents corrosion and cavitation
- High reliability and durability together with reduced maintenance requirement and wear parts

Fuel System

- Fuel filter with water-separator
- Direct fuel injection system

Oil System

- Spin-on full flow lub oil filter
- Wet steel sump with filler and dipstick

Control Panel

Manual or Automatic start control panel

- 12 volt Electric system
- Expansion module for CAN communication
- Control version for synchronizing a single genset with mains
- Control version for synchronizing with mains without blackout

Rating Table : The Genset NEF N45SM3 Engine.

Engine type		NEF N45SM3
Speed	min ⁻¹ rpm	1500
Frequency	Hz	50
Engine Power		
Prime power (PRP)	kVA kW	80 64
Limited time running power (LTP)	kVA kW	88 70.5
Fuel consumption		
100 % Load	g/kWh	216.7
80 % Load	g/kWh	215.4
50 % Load	g/kWh	214.4

PRP* kVA/KW :

The prime power is the maximum power available with varying loads for an unlimited number of hours. The average power output during a 24 hour period of operation must not exceed 80% of the declared prime power between the prescribed maintenance intervals and at standard environmental conditions. A 10% overload is permissible for 1 hour every 12 hours of operation.

LTP** kVA/KW :

The stand-by power is the maximum power available for a period of 500 hours/year with a mean load factor of 90% of the declared stand-by power. No kind of overloads is permissible for this use.

Scope of supply :

The engine and alternator are mounted together forming a rigid monoblock, the shoulders are connected by inflexible disc connection. The mono-block is mounted on a steel base frame through silent blocks. The base frame is including a fuel tank. Starting is electric and it contains a battery. The generator monitoring system consists of a control module.

Technical Data

Engine type	NEF N45SM3	
Numer of cylinder	4	
Bore x Stroke	mm	104 x 132
Displacement	l	4.5
Speed	rpm	1500
Engine Power PRP	KW	64
Engine Power LTP	KW	70.5
Cooling Type	water	
Injection Type	Direct	
Air intake restriction, clean filter	kPa	2
Air intake restriction, dirty filter	kPa	5
Max standby power at rated RPM	KW/HP	73/99.3
Coolant capacity	Litres	8.5
Battery	Ah	125
Oil Tank capacity	Litres	12.8
Electrical systems	V	12
Exhaust gas Temperature	°C	516

Engine Illustration

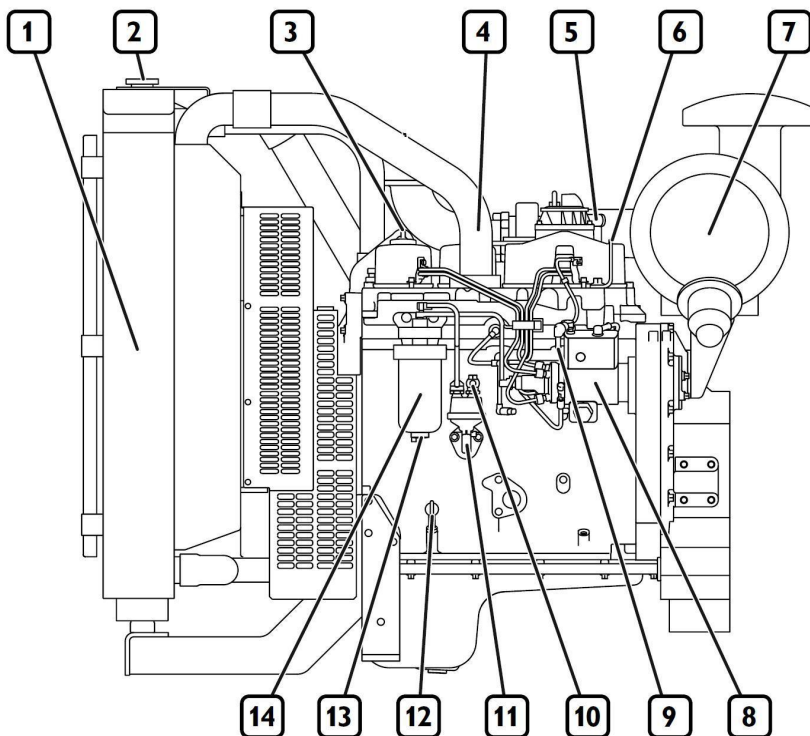

Engine Description NEF N45SM3

- 1 Heat exchangers
- 2 Coolant filler cap
- 3 Oil filler cap
- 4 Engine air inlet manifold
- 5 Oil vapor bleeder
- 6 Lifting U-bolt
- 7 Air filter
- 8 Injection Pump
- 9 Fuel outlet connector to tank
- 10 Fuel inlet manifold from tank
- 11 Hand pump
- 12 Oil dipstick
- 13 Fuel Filter condensation drain plug
- 14 Fuel Filter

Engine Description NEF N45SM3

- 1 Exhaust manifold
- 2 Turbocharger air intake
- 3 Turbo charging air outlet
- 4 Turbocharger
- 5 Exhaust outlet
- 6 Lifting U-bolt
- 7 Coolant outlet manifold from engine
- 8 Location of thermostatic valve
- 9 Engine coolant inlet connector sleeve
- 10 Fan
- 11 Alternator
- 12 Lubricant oil discharge plug
- 13 Oil filter
- 14 Electrical starter

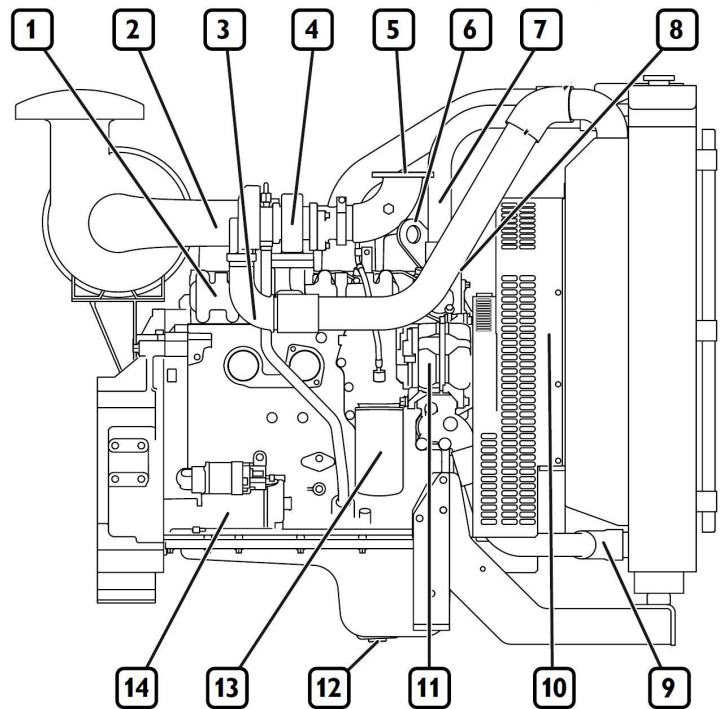

Dimensions

Engine type	Length	Width	Height
NEF N45SM3 mm	1259	657	1016