

## GREEN POWER KOHLER DIESEL ENGINE

---

1500 RPM	Type GP27KH
----------	-------------

The Engine with integrated Water cooling

**Engine:** KDI 250 4M

### Technical description

- 4 stroke water-cooled diesel engine.
- Conical power take-off on the crankshaft.
- Counterclockwise rotation.
- Direct injection.
- Forced lubrication with oil pump.
- The centrifugal mass governor.
- Built-in full-flow oil filter.
- Oil breathing blow-by with the safety device.
- Automatic extra fuel starting device.
- Self bleeding fuel system.
- Torque Regulator.
- Automatic compression release.
- Die-cast aluminum crankcase with integrated cast iron cylinder liners.
- The aluminum alloy cylinder head.
- Built rigid feet.

### Benefits

- Low noise emission, cost savings as no noise attenuation measures are required
- Low installation costs
- Excellent load takeover characteristics ensure prompt power supply
- Combined oil cooling and lubrication prevents corrosion and cavitation
- High reliability and durability together with reduced maintenance requirement and wear parts

Scope of supply :

The engine and alternator are mounted together forming a rigid monoblock, the shoulders are connected by inflexible disc connection. The mono-block is mounted on a steel base frame through silent blocks. The base frame is including a fuel tank. Starting is electric and it contains a battery.

Rating Table : The Genset KDI 250 4M Engine

Engine type	KDI 250 4M		
Speed	min <sup>-1</sup>   rpm	1500	
Frequency	Hz	50	
Engine Power			
Prime power (PRP)	kVA   kW	27	21.6
Limited time running power (LTP)	kVA   kW	30	24

Dimensions (mm)

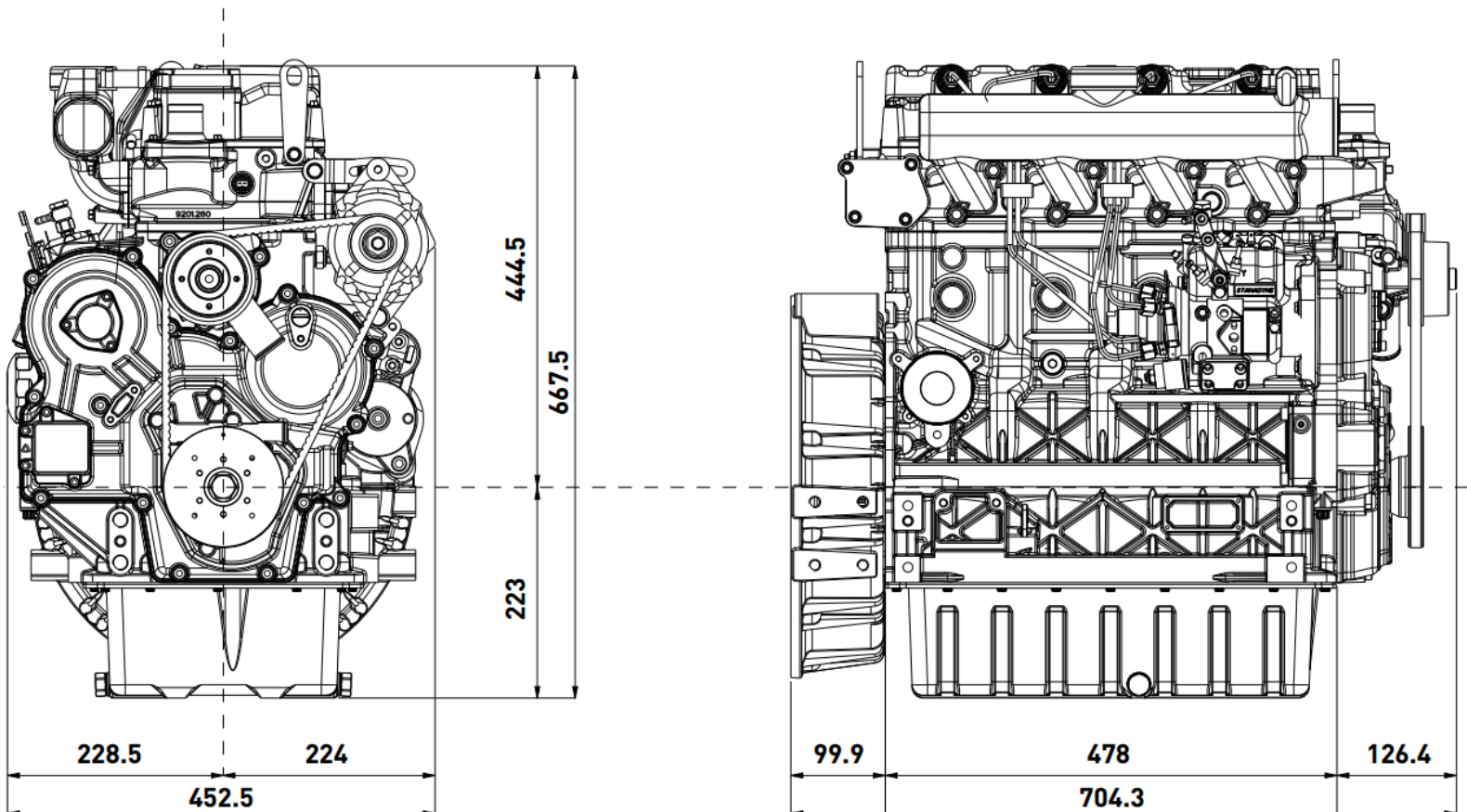

## Technical Data

Engine type	<b>KDI 250 4M</b>	
Numer of cylinder	4	
Bore x Stroke	mm	88 x 102
Displacement	cm <sup>3</sup>	2482
Exhaust gas flow	kg/h	116
Engine Power PRP	KW	21.6
Engine Power LTP	KW	24
Cooling Type	Water	
Injection Type	Direct	
Fuel consumption	lt/hr	5.2
Rating	HP/KW	33.6/24.7
Max. exhaust gas temperature	C°	520

### Special accessories

Power take-off flywheel side  
 PTO with flanging and special shaft  
 Internal dynamic balancer  
 Oil bath air cleaner  
 Electric start 12V / 24 V  
 Keyswitch panel  
 Emergency stop through electrovalve  
 Accelerator and stop remote control  
 Fuel lift pump  
 Oil pressure switch  
 Glow plug on intake manifold  
 Recoil with denoising cover  
 Grass protection for engine cooling  
 Oil level sensor switch  
 High capacity oil sump

### Special accessories

Recoil starting  
 Automatic compression release  
 Dry air cleaner  
 Fuel tank  
 Muffler with guard  
 Accelerator and stop manual control  
 Manual compression release  
 Automatic deaeration on injection pump  
 Net oil filter  
 Conical power take-off  
 External fuel filter



## Greenpower AB

Helsingborgsvägen Varalöv  
 26296 Ängelholm, Sweden  
 Tel: +46 431-22240  
 E-mail: info@greenpower.se  
 web:www.greenpower.se