

GREEN POWER PERKINS DIESEL ENGINE

1500 RPM	Type GP1022P
----------	--------------

The Engine with integrated water cooling

Engine: 4008-TAG2A

Technical description

- Optimized cast iron cylinder block with optimum distribution of forces
- Piston cooling for low piston temperature and reduced ring temperature
- Powerful but 30.6 litre naturally aspirated 8 cylinder compact Engine
- Crankshaft hardened bearing surfaces and fillets for moderate on main and big end bearings
- Keystone top compression rings for long service life
- Replaceable valve guides and valve seats
- Thermostatically controlled system with gear driven circulation pump
- Lift eyelets
- High inertia flywheel to SAE J620
- Flywheel for flexible coupling and friction clutch
- Front engine mounting brackets

Benefits

- Low noise emission, cost savings as no noise attenuation measures are required
- Long service intervals: 1000 hour oil change intervals and low fuel consumption bring savings in Operating costs
- Low installation costs
- Excellent load takeover characteristics ensure prompt power supply
- Combined oil cooling and lubrication prevents corrosion and cavitation
- High reliability and durability together with reduced maintenance requirement and wear parts

Fuel System

- Mechanically governed cassette type fuel injection pump
- Split element fuel filter

Oil System

- Spin-on full flow lub oil filter
- Wet steel sump with filler and dipstick

Control Panel

Manual or Automatic start control panel

- 12 volt Electronic shut Off Solenoid(ESOS) energised to run
- 12 volt starter motor and 12 volt 15 amp alternator with DC output
- Glow plug cold start aid and heater/starter switch
- Oil pressure and coolant temperature switches

Rating Table : The Genset 4008-TAG2A Engine.

Engine type	4008-TAG2A		
Speed	min ⁻¹ rpm	1500	
Frequency	Hz	50	
Engine Power			
Prime power (PRP)	kVA kW	1022	818
Limited time running power (LTP)	kVA kW	1125	900
Fuel consumption			
Standby power	g/KWh l/hr	209	240
100 % of Prime power	g/KWh l/hr	206	215
75 % of Prime power	g/KWh l/hr	206	162
50 % of Prime power	g/KWh l/hr	207	111

PRP* kVA/KW :

Prime power is available for an unlimited number of annual hours in variable load application. A 10% overload capability is available for a period of 1 hour within a 12-hour period of operation.

LTP** kVA/KW :

The standby power rating is applicable for supplying emergency power for the duration of a utility power interruption. No overload, utility parallel or negotiated outage operation capability is available at this rating.

Scope of supply :

The engine and alternator are mounted together forming a rigid monoblock, the shoulders are connected by inflexible disc connection. The mono-block is mounted on a steel base frame through silent blocks. The base frame is including a fuel tank. Starting is electric and it contains a battery. The generator monitoring system consists of a control module.

Technical Data

Engine type	4008-TAG2A	
Numer of cylinder	8	
Bore x Stroke	mm	160 x 190
Displacement	l	30.6
Compression ratio	13.6:1	
Engine Power PRP	KW	818
Engine Power LTP	KW	900
Cooling Type	water	
Injection Type	Direct	
Dry weight	Kg	4360
Max standby power at rated RPM	KW/HP	962/1290
Coolant capacity	Litres	149
Battery	Ah	1600
Oil Tank capacity	Litres	153
Exhaust gas flow	m ³ /min	195
Exhaust gas Temperature	°C	438

Dimensions

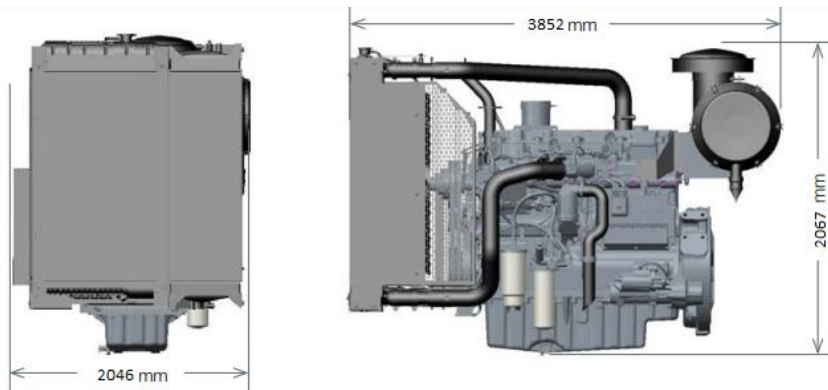

Engine type		Length	Width	Height
4008-TAG2A	mm	3852	2046	2067

Engine Illustration

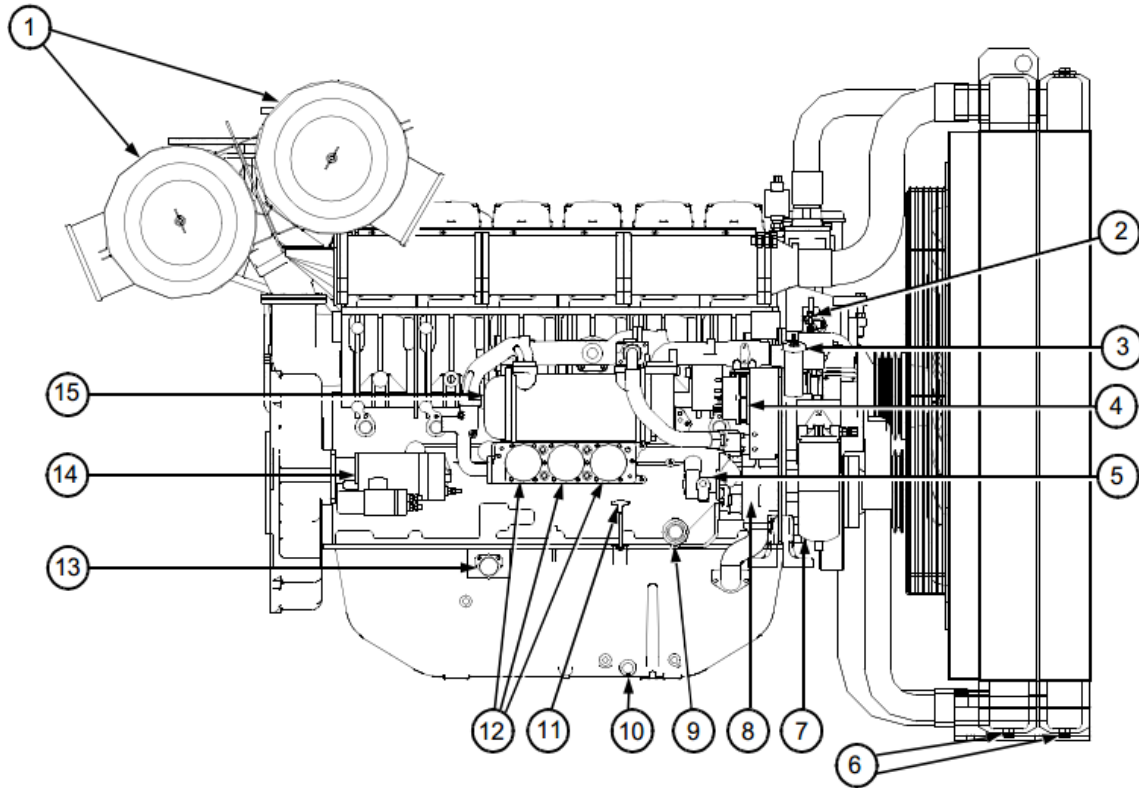

Engine Description 4008-TAG2A

- 1 Twin air filters
- 2 Governor lever
- 3 Filler cap for the lubricating oil
- 4 24 Volt alternator
- 5 Fuel lift pump
- 6 Radiator drain plugs
- 7 Fuel filter/water separator
- 8 Engine oil pump
- 9 Fuel hand prime pump
- 10 Drain plug for the lubricating
- 11 Lubricating oil dipstick
- 12 Lubricating oil filters
- 13 Starter relay
- 14 24 Volt Starter motor
- 15 Lubricating oil cooler

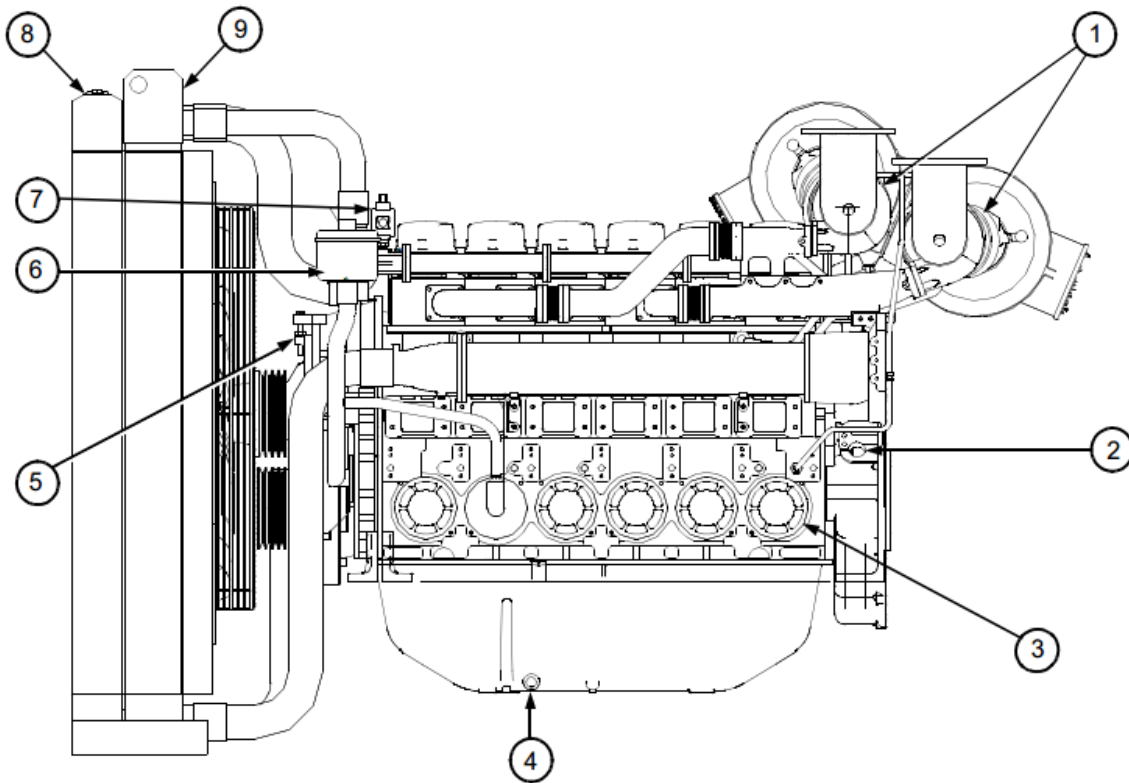

Engine Description
4008-TAG2A

- 1 Twin turbochargers
- 2 View hole for timing mark
- 3 Crankshaft inspection cover
- 4 Sump drain plug
- 5 Drive belt tension screw
- 6 Engine breather
- 7 Engine protection switch
- 8 Air to air charge cooler
- 9 Radiator



Greenpower AB
Helsingborgsvägen Varalöv
262 96 Ängelholm, Sweden
Tel: +46 431 222 40
E mail: info@greenpower.se
web:www.greenpower.se