

GREEN POWER PERKINS DIESEL ENGINE

1500 RPM	Type GP135P
----------	-------------

The Engine with integrated water cooling

Engine: 1106A-70TG1

Technical description

- Optimized cast iron cylinder block with optimum distribution of forces
- Piston cooling for low piston temperature and reduced ring temperature
- Powerful but 7 litre naturally aspirated 6 cylinder compact Engine
- Crankshaft hardened bearing surfaces and fillets for moderate on main and big end bearings
- Keystone top compression rings for long service life
- Replaceable valve guides and valve seats
- Thermostatically controlled system with gear driven circulation pump
- Lift eyelets
- High inertia flywheel to SAE J620
- Flywheel for flexible coupling and friction clutch
- Front engine mounting brackets

Benefits

- Low noise emission, cost savings as no noise attenuation measures are required
- Long service intervals: 1000 hour oil change intervals and low fuel consumption bring savings in Operating costs
- Low installation costs
- Excellent load takeover characteristics ensure prompt power supply
- Combined oil cooling and lubrication prevents corrosion and cavitation
- High reliability and durability together with reduced maintenance requirement and wear parts

Fuel System

- Mechanically governed cassette type fuel injection pump
- Split element fuel filter

Oil System

- Spin-on full flow lub oil filter
- Wet steel sump with filler and dipstick

Control Panel

Manual or Automatic start control panel

- 12 volt Electronic shut Off Solenoid(ESOS) energised to run
- 12 volt starter motor and 12 volt 15 amp alternator with DC output
- Glow plug cold start aid and heater/starter switch
- Oil pressure and coolant temperature switches

Rating Table : The Genset 1106A-70TG1 Engine.

Engine type	1106A-70TG1		
Speed	min ⁻¹ rpm	1500	
Frequency	Hz	50	
Engine Power			
Prime power (PRP)	kVA kW	135	108
Limited time running power (LTP)	kVA kW	150	120
Fuel consumption			
Prime power	g/KWh l/hr	203	30.2
75 % of Prime power	g/KWh l/hr	204	22.7
50 % of Prime power	g/KWh l/hr	213	15.9
25 % of Prime power	g/KWh l/hr	242	9.0

PRP* kVA/KW :

Prime power is available for an unlimited number of annual hours in variable load application. A 10% overload capability is available for a period of 1 hour within a 12-hour period of operation.

LTP** kVA/KW :

The standby power rating is applicable for supplying emergency power for the duration of a utility power interruption. No overload, utility parallel or negotiated outage operation capability is available at this rating.

Scope of supply :

The engine and alternator are mounted together forming a rigid monoblock, the shoulders are connected by inflexible disc connection. The mono-block is mounted on a steel base frame through silent blocks. The base frame is including a fuel tank. Starting is electric and it contains a battery. The generator monitoring system consists of a control module.

Technical Data

Engine type	1106A-70TG1		
Numer of cylinder	6		
Bore x Stroke	mm	105 x 135	
Displacement	l	7.0	
Compression ratio	18.2:1		
Engine Power PRP	KW	108	
Engine Power LTP	KW	120	
Cooling Type	water		
Injection Type	Indirect		
Dry weight	Kg	739	
Air Intake	m ³ /min	7.6	
Max standby power at rated RPM	KW/HP	122.7/164.5	
Coolant capacity	Litres	21	
Battery	Ah	250	
Oil Tank capacity	Litres	18	
Exhaust gas flow	m ³ /min	18.9	
Exhaust gas Temperature	°C	561	

Dimensions

Engine type		Length	Width	Height
1106A-70TG1	mm	1509	760	1042

Engine Illustration

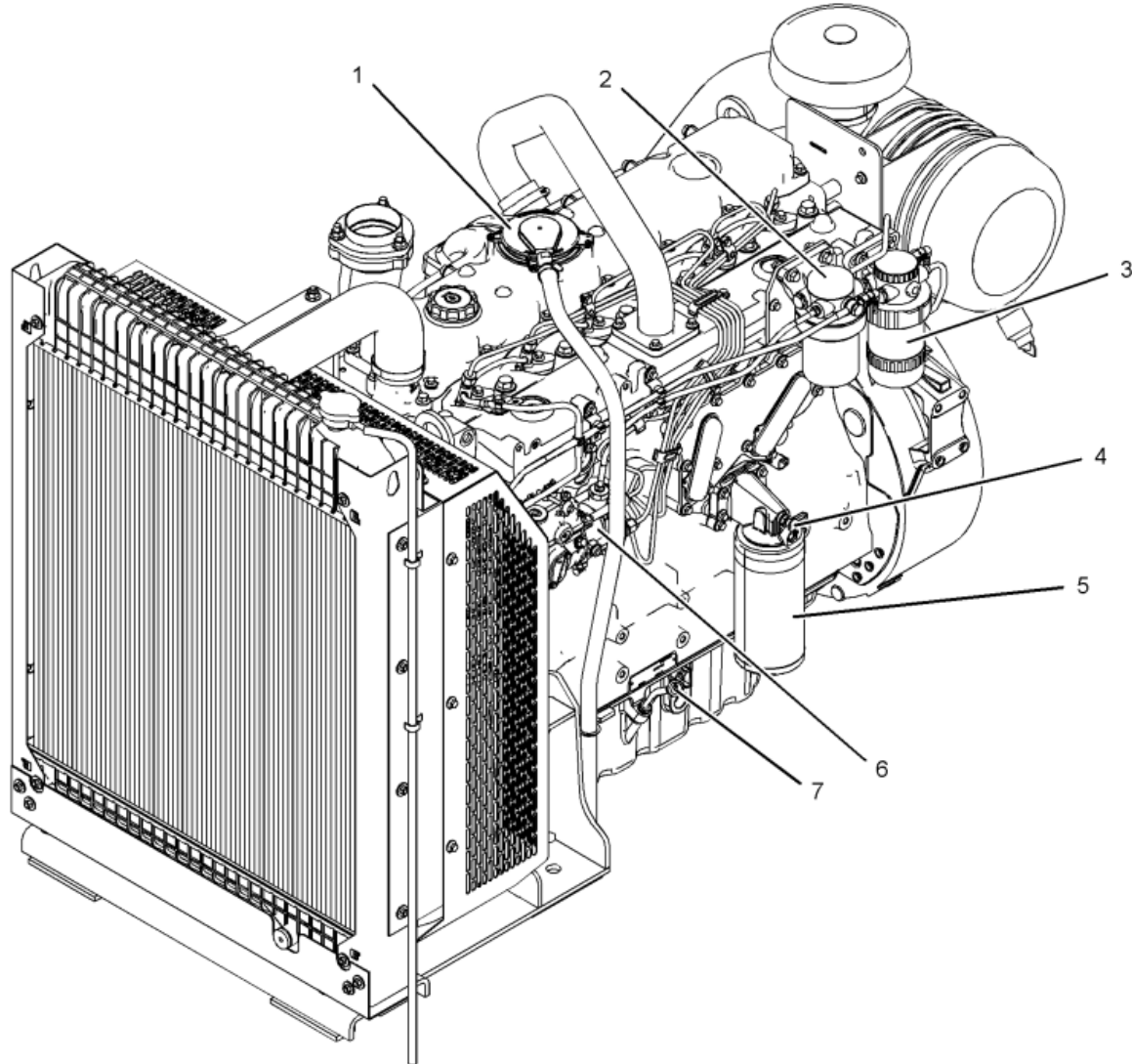

- Engine Description**
1106A-70TG1
- 1 Crankcase breather
 - 2 Secondary fuel filters
 - 3 Primary fuel filter
 - 4 Oil sampling valve
 - 5 Oil filter
 - 6 Fuel injection pump
 - 7 Oil gauge (dipstick)

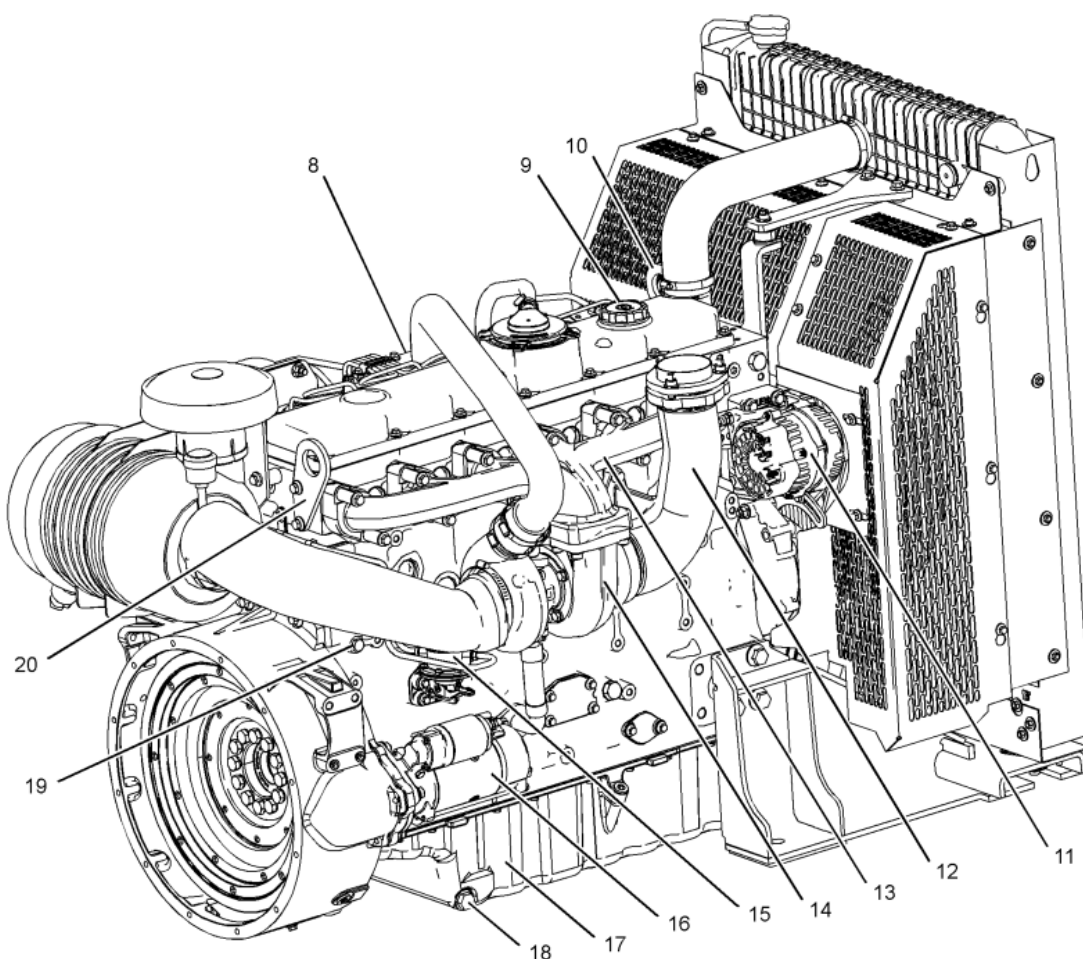

Engine Description

1106A-70TG1

- 8 Air intake
- 9 Oil filler
- 10 Front lifting eye
- 11 Alternator
- 12 Exhaust elbow
- 13 Exhaust manifold
- 14 Turbocharger
- 15 Fuel priming pump
- 16 Starting motor
- 17 Oil pan
- 18 Drain plug (oil)
- 19 Drain plug (coolant)
- 20 Rear lifting eye