

GREEN POWER PERKINS DIESEL ENGINE

1500 RPM	Type GP450P
----------	-------------

The Engine with integrated water cooling

Engine: 2506A-E15TAG1

Technical description

- Optimized cast iron cylinder block with optimum distribution of forces
- Piston cooling for low piston temperature and reduced ring temperature
- Powerful but 15.2 litre naturally aspirated 6 cylinder compact Engine
- Crankshaft hardened bearing surfaces and fillets for moderate on main and big end bearings
- Keystone top compression rings for long service life
- Replaceable valve guides and valve seats
- Thermostatically controlled system with gear driven circulation pump
- Lift eyelets
- High inertia flywheel to SAE J620
- Flywheel for flexible coupling and friction clutch
- Front engine mounting brackets

Benefits

- Low noise emission, cost savings as no noise attenuation measures are required
- Long service intervals: 1000 hour oil change intervals and low fuel consumption bring savings in Operating costs
- Low installation costs
- Excellent load takeover characteristics ensure prompt power supply
- Combined oil cooling and lubrication prevents corrosion and cavitation
- High reliability and durability together with reduced maintenance requirement and wear parts

Fuel System

- Mechanically governed cassette type fuel injection pump
- Split element fuel filter

Oil System

- Spin-on full flow lub oil filter
- Wet steel sump with filler and dipstick

Control Panel

Manual or Automatic start control panel

- 12 volt Electronic shut Off Solenoid(ESOS) energised to run
- 12 volt starter motor and 12 volt 15 amp alternator with DC output
- Glow plug cold start aid and heater/starter switch
- Oil pressure and coolant temperature switches

Rating Table : The Genset 2506A-E15TAG1 Engine.

Engine type	2506A-E15TAG1		
Speed	min ⁻¹ rpm	1500	
Frequency	Hz	50	
Engine Power			
Prime power (PRP)	kVA kW	450	360
Limited time running power (LTP)	kVA kW	495	396
Fuel consumption			
Standby power	g/KWh l/hr	198	104
100 % of Prime power	g/KWh l/hr	199	95
75 % of Prime power	g/KWh l/hr	200	72
50 % of Prime power	g/KWh l/hr	210	50

PRP* kVA/KW :

Prime power is available for an unlimited number of annual hours in variable load application. A 10% overload capability is available for a period of 1 hour within a 12-hour period of operation.

LTP** kVA/KW :

The standby power rating is applicable for supplying emergency power for the duration of a utility power interruption. No overload, utility parallel or negotiated outage operation capability is available at this rating.

Scope of supply :

The engine and alternator are mounted together forming a rigid monoblock, the shoulders are connected by inflexible disc connection. The mono-block is mounted on a steel base frame through silent blocks. The base frame is including a fuel tank. Starting is electric and it contains a battery. The generator monitoring system consists of a control module.

Technical Data

Engine type	2506A-E15TAG1	
Numer of cylinder	6	
Bore x Stroke	mm	137 x 171
Displacement	l	15.2
Compression ratio	16:1	
Engine Power PRP	KW	360
Engine Power LTP	KW	396
Cooling Type	water	
Injection Type	Indirect	
Dry weight	Kg	1633
Max standby power at rated RPM	KW/HP	451/604
Coolant capacity	Litres	58
Battery	Ah	800
Oil Tank capacity	Litres	62
Exhaust gas flow	m ³ /min	94
Exhaust gas Temperature	°C	550

Dimensions

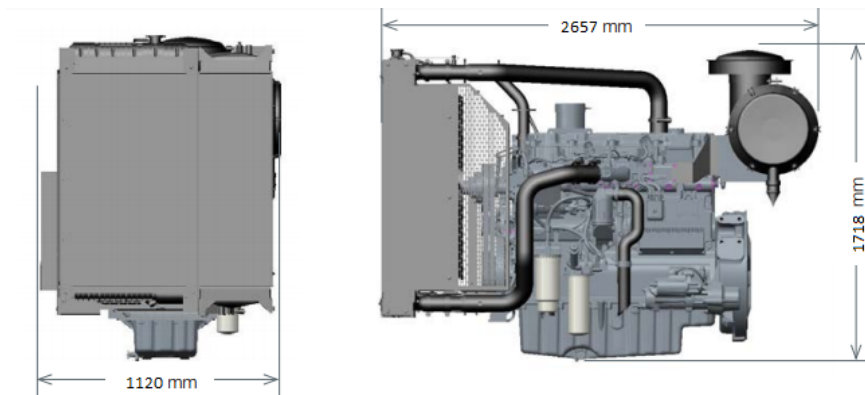

Engine type	Length	Width	Height
2506A-E15TAG1 mm	2657	1120	1718

Engine Illustration

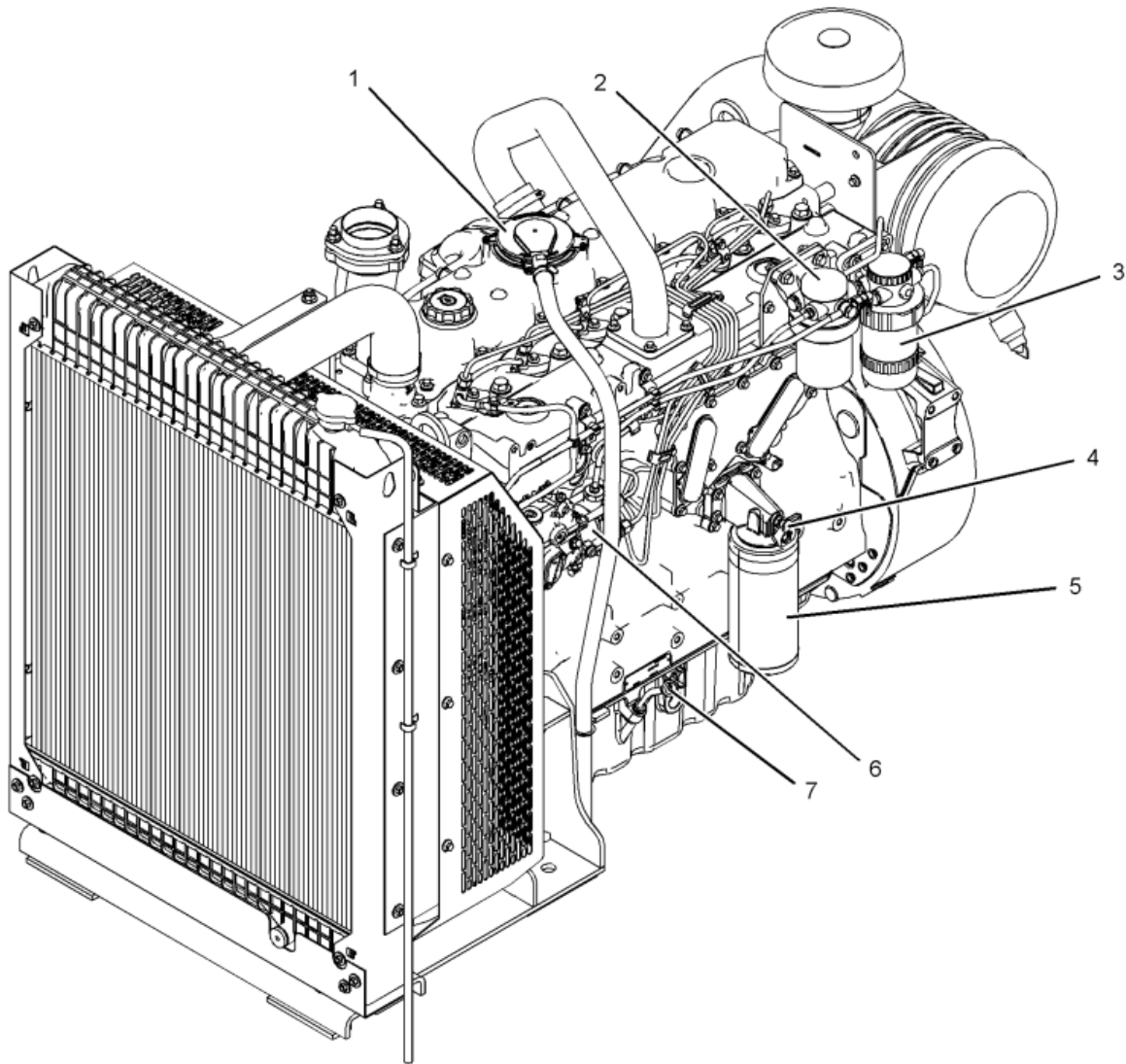

Engine Description

2506A-E15TAG1

- 1 Crankcase breather
- 2 Secondary fuel filters
- 3 Primary fuel filter
- 4 Oil sampling valve
- 5 Oil filter
- 6 Fuel injection pump
- 7 Oil gauge (dipstick)

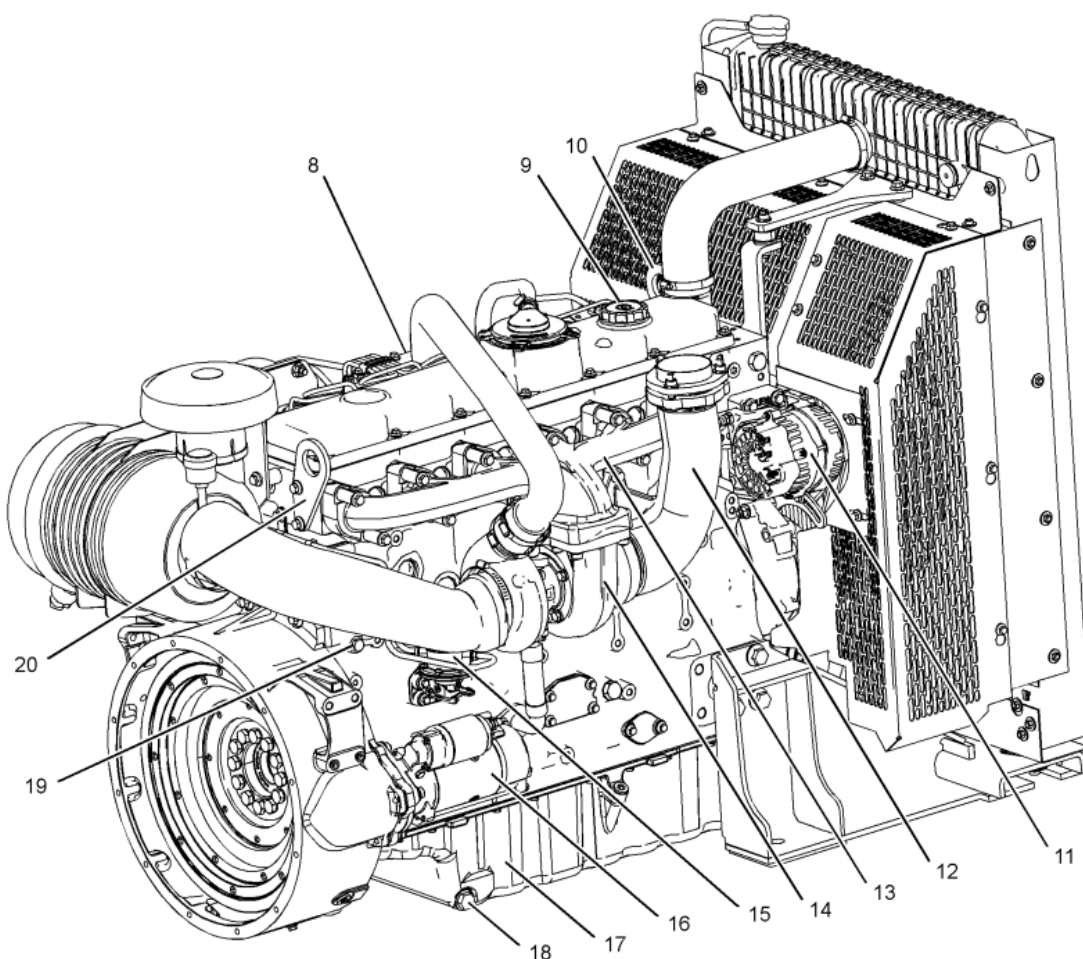

Engine Description

2506A-E15TAG1

- 8 Air intake
- 9 Oil filler
- 10 Front lifting eye
- 11 Alternator
- 12 Exhaust elbow
- 13 Exhaust manifold
- 14 Turbocharger
- 15 Fuel priming pump
- 16 Starting motor
- 17 Oil pan
- 18 Drain plug (oil)
- 19 Drain plug (coolant)
- 20 Rear lifting eye