

GREEN POWER VOLVO DIESEL ENGINE

1500 RPM	Type GP185VO
-----------------	---------------------

The Engine with integrated water cooling

Engine: TAD732GE

Technical description

- Optimized cast iron cylinder block with optimum distribution of forces
- Piston cooling for low piston temperature and reduced ring temperature
- Drop forged steel connecting rods
- Crankshaft hardened bearing surfaces and fillets for moderate on main and big end bearings
- Keystone top compression rings for long service life
- Replaceable valve guides and valve seats
- Three PTO positions at flywheel
- Lift eyelets
- Flywheel housing with connection acc. to SAE 2 and SAE 3
- Flywheel for flexible coupling and friction clutch
- Transport brackets

Benefits

- Low noise emission, cost savings as no noise attenuation measures are required
- Long service intervals: 1000 hour oil change intervals and low fuel consumption bring savings in Operating costs
- Low installation costs
- Excellent load takeover characteristics ensure prompt power supply
- Combined oil cooling and lubrication prevents corrosion and cavitation
- High reliability and durability together with reduced maintenance requirement and wear parts

Model Designation

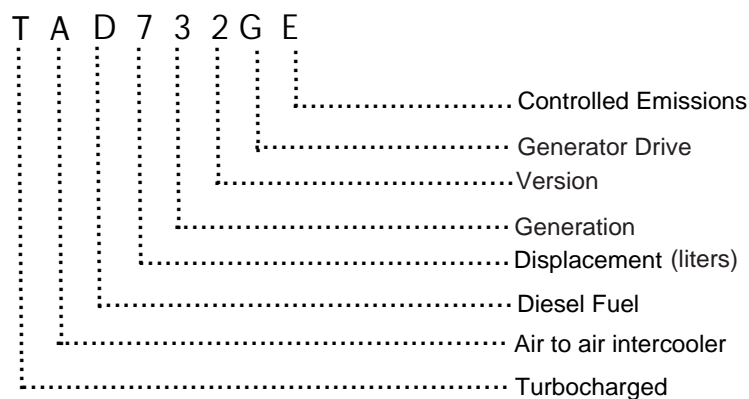

Control Panel

Manual or Automatic start control panel

- Manual or automatic remote boot controller, selector switch for Off, Man and Auto with the key.
- Complete motor protection functions with alarms visualized via LEDs in the front.
- The control unit 6 is set via DIP switches in the rear part of the case.
- Standard circuit breaker and differential relay.

Rating Table : The Genset TAD732GE Engine

Engine type	TAD732GE		
Speed	min ⁻¹ rpm	1500	
Frequency	Hz	50	
Engine Power			
Prime power (PRP)	kVA kW	185	148
Limited time running power (LTP)	kVA kW	204	163
Spec. fuel consumption PRP (LTP)			
100 % load	g/KWh lb/hph	214	0.347
75 % load	g/KWh lb/hph	212	0.444
50% load	g/KWh lb/hph	215	0.348
25 % load	g/KWh lb/hph	234	0.379

PRP* kVA/KW :

Available electrical power (at variable load) in a medium of 80% of the indicated maximum power. A 10% overload capacity is available.

LTP** kVA/KW :

Available electrical power load (at variable load) for a maximum of 500 hours per year. No overload capability available

Scope of supply :

The engine and alternator are mounted together forming a rigid monoblock, the shoulders are connected by inflexible disc connection. The mono-block is mounted on a steel base frame through silent blocks. The base frame is including a fuel tank. Starting is electric and it contains a battery. The generator monitoring system consists of a control module.

Technical Data

Engine type	TAD732GE	
Numer of cylinder	6	
Bore x Stroke	mm	108 x 130
Displacement	l	7.15
Compression ratio	18:1	
Engine Power PRP	KW	148
Engine Power LTP	KW	163
Cooling Type	water	
Injection Type	Directly	
Max allowable Back pressure	Kpa	5
Max Permitted air Intake restriction	Kpa	3.5
Standard Governor	Mechanical	
Oil system capacity	Litres	34
Battery	Ah	60
Starting engine	KW	5.5
Exhaust gas flow	m ³ /min	35.1
Exhaust gas Temperature	°C	542

Dimensions

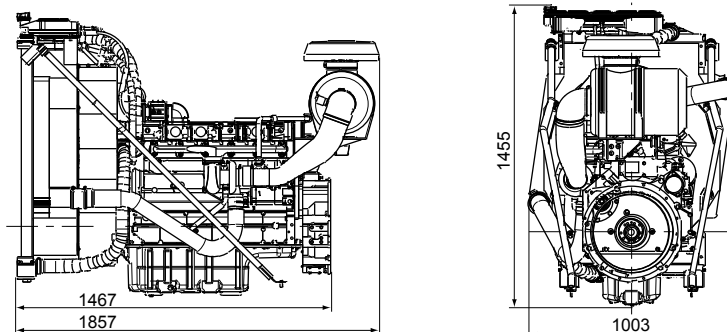

Engine type	Length	Width	Height
TAD732GE mm	1857	1003	1455

Engine Illustration

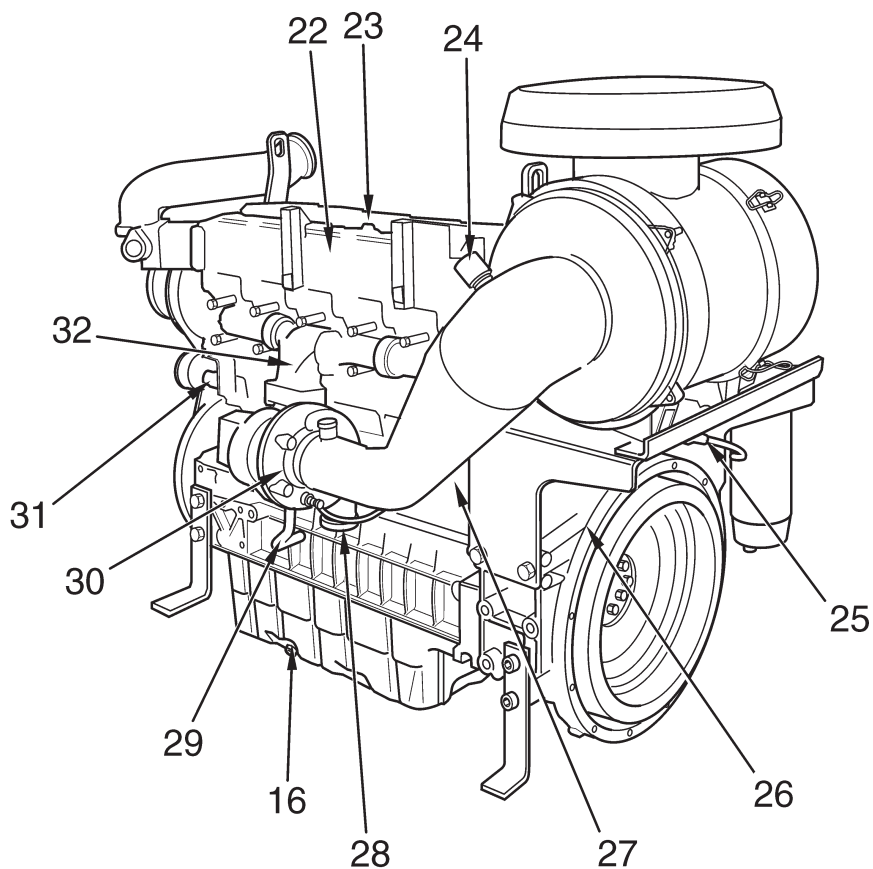
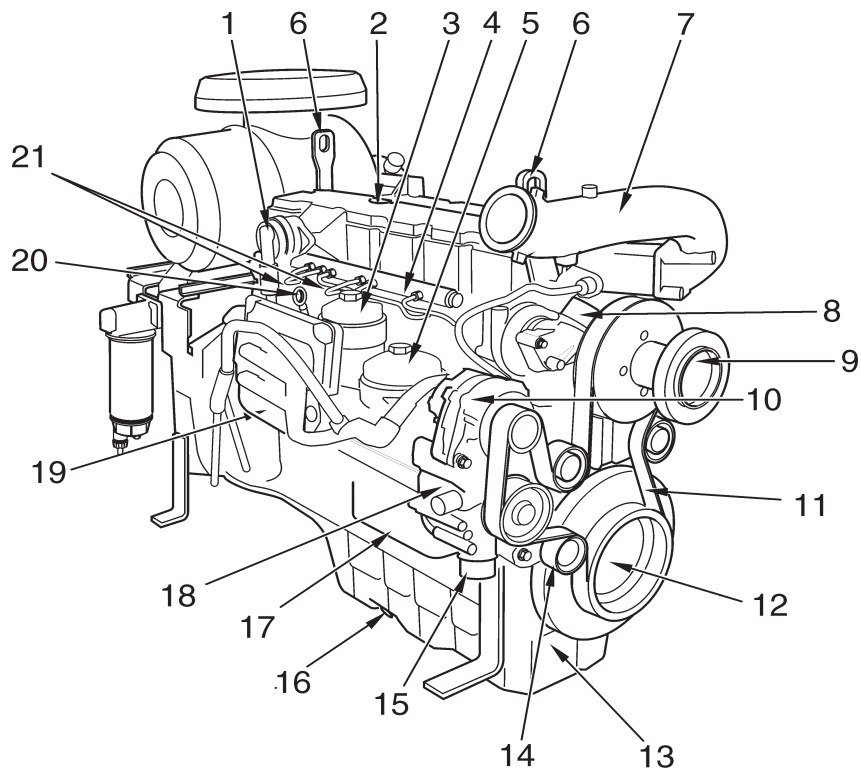

Engine Description

TAD734GE

1. Crankcase ventilation
2. Oil filter
3. Fuel filter
4. Common rail unit
5. Oil filters
6. Lifting eyes
7. Inlet, after charge-air cooler
8. Coolant outlet
9. Fan hub
10. Alternator
11. Drive belt
12. Damper and belt pulley
13. Oil pan
14. Tensioner pulley
15. Coolant inlet, to engine
16. Drain plug, oil pan
17. Oil cooler
18. Coolant pump
19. Outlet, engine heater
20. Dipstick
21. High pressure pumps
22. Air inlet pipe
23. Valve cover
24. Indicator, air filter
25. Fuel pump
26. Flywheel housing
27. Starter motor guard
28. Charge air, to coolers
29. Oil pipe from the turbo
30. Turbo
31. Relay
32. Exhaust manifold



Greenpower AB

Helsingborgsvägen Varalöv
 262 96 Ängelholm, Sweden
 Tel: +46 431-222 40
 E-mail: info@greenpower.se
 web: www.greenpower.se