

# InteliGen NTC BaseBox

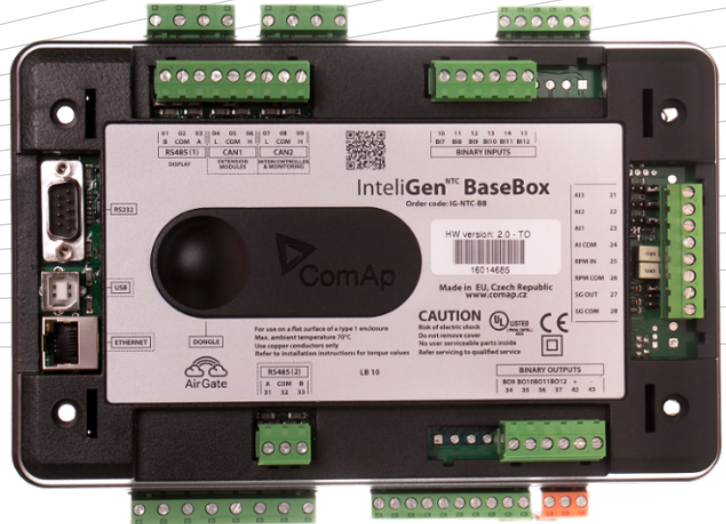

## Gen-set Controller

# Datasheet

### Product description

- Comprehensive paralleling gen-set controller
- Parallel operation up to 32 gen-sets
- High level control for complex systems
- CHP and gas engine controller

### Key features

- Load sharing and VAR sharing via CAN
- Virtual shared inputs and outputs via CAN
- Support of wide range of applications
- Single or multiple gen-sets in parallel to mains operation with automatic back up function, multiple island operation
- Advanced power management function
- Customizable load control in parallel to mains
- Wide range of ECU support
- Extended communication capabilities
  - Full Modbus slave support
  - GPS and AirGate support and more
- Highly configurable
  - Timers, Internal PLC, Force values and more
- Compatible with ComAp's InteliVision displays
- Active e-mail messaging and SMS

Extensive built-in protection functions

- Standard protections
- User configurable protection

Extendable with ComAp's extension modules

### Application overview

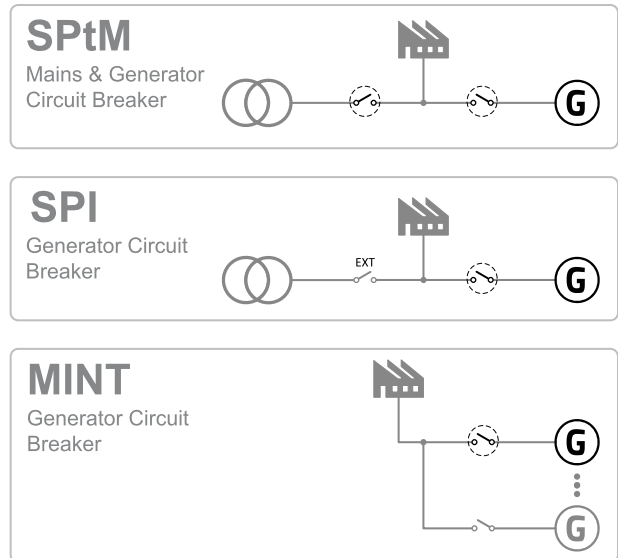

## Technical data

### Power supply

Power supply range	8-36 V DC
Power supply drop-out immunity	20 ms (from 8 V)
Power consumption	0.4 A / 8 VDC
	0.15 A / 24 VDC
	0.1 A / 36 VDC
RTC battery	10 years (replaceable by official service)
Fusing	2 A (without BOUT consumption)
Max. Power Dissipation	16 W

### Operating conditions

Operating temperature	-40 °C to +70 °C
Storage temperature	-40 °C to +80 °C
Max. operating altitude	2000 m above sea level
	4000 m above sea level for max Ph-Ph voltage 400V AC
Operating humidity	95 % w/o condensation
Vibration	5-25 Hz, $\pm 1.6$ mm
	25-100 Hz, a = 4 g
Shocks	a=200 m/s <sup>2</sup>
Heat radiation	16 W

### Voltage measurement

Measurement inputs	3 ph-n Gen voltage
	3 ph-n Mains voltage/Bus voltage
Measurement range	110V / 277V
Max allowed voltage	125 % ph-n
Accuracy	1 % of 110V / 277V
Frequency range	40-70 Hz (accuracy 0.1 Hz)
	45-55 Hz (accuracy <0.01 Hz)
Input impedance	0.6 M $\Omega$ ph-ph, 0.3 M $\Omega$ ph-n

### Current measurement

Measurement inputs	3 ph Gen current
	1 ph Mains current galvanically isolated
Measurement range	1 A / 5 A
Max allowed continuous current	200 % / 200 %
Accuracy	2 % of 1 A / 5 A
Input impedance	< 0.1 $\Omega$

### Binary inputs

Number	16, non-isolated
Input resistance	4.7 k $\Omega$
Close/Open indication	0-2 V DC close contact >4 V DC open contact

### Binary outputs

Number	16, non-isolated
Max current	0.5 A (2 A per group) group1: BO1-8; group2: 9-12
Switching to	Negative/positive supply terminal

### Analog inputs

Number	4, non-isolated
Type	Switchable (Voltage, Resistance, Current)
Resolution	10 bits, max 4 decimals
Range	0-5 V DC / 0-2500 $\Omega$ / 0-20 mA
Input impedance	>100 k $\Omega$ / >100 k $\Omega$ / 180 $\Omega$
Accuracy	$\pm 1$ % of meas. value $\pm 5$ mV
	$\pm 2$ % of meas value $\pm 2$ $\Omega$
	$\pm 1$ % of meas value $\pm 0.5$ mA

### Magnetic pick-up

Voltage input range	2 Vpk-pk to 50 Veff
Frequency input range	4 Hz to 15 kHz
Frequency measurement tolerance	0.2 %

### Voltage regulator output

Type	5 V TTL PWM / $\pm 10$ V DC with IG-AVRi interface
------	--

### Speed governor output

Voltage output	$\pm 10$ V DC / max. 10 mA
Voltage output via resistor	$\pm 10$ V DC via 10 k $\Omega$ resistor / max. 1 mA
PWM	500÷3000 Hz / 5 V / max. 10 mA

### Communications

RS232	Direct / Modbus, non-isolated
RS485	Direct / Modbus, isolated
Display port	Non-isolated RS485, only terminal connection
USB port	Direct, Isolated
Ethernet port	galvanically isolated
	LAN/Internet, Modbus TCP, AirGate
CAN1	External modules, 250 kbps, max 200 m, Isolated
CAN2	Intercontroller and comm extensions, 250 / 50 kbps, max 200 / 1000 m, Isolated

## Dimensions, terminals and mounting

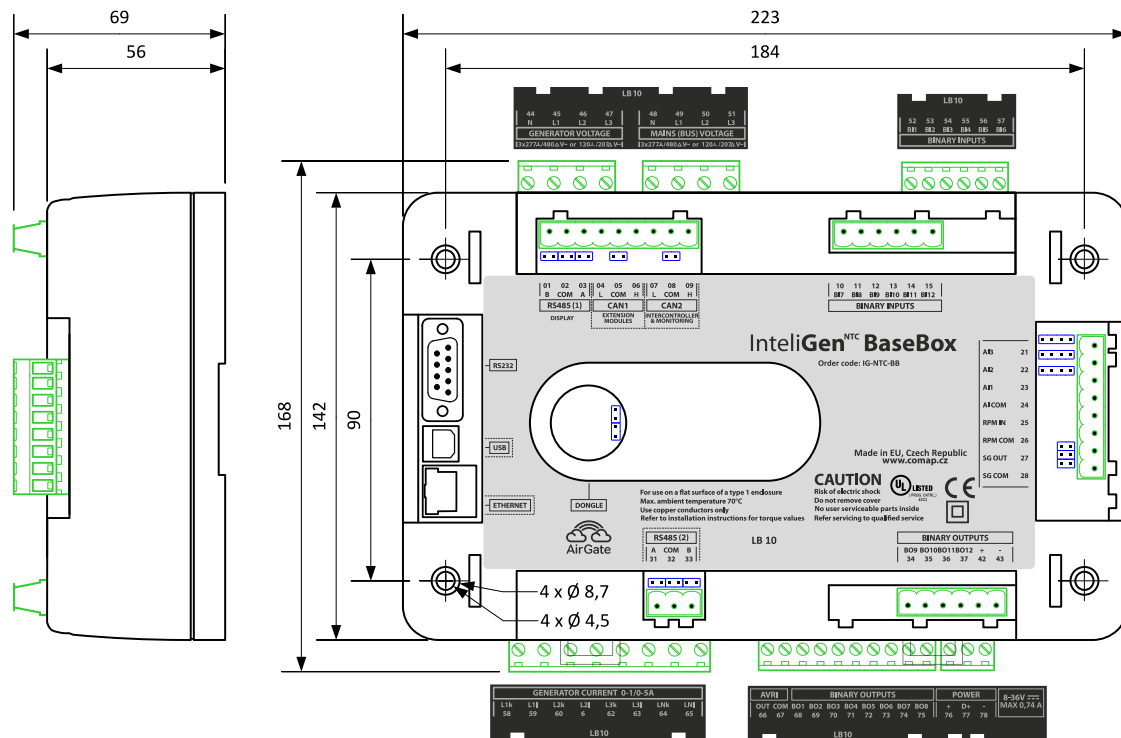

Panel door mounting  
with IntelliVision 5

DIN-rail mounting

Panel door mounting  
with IntelliVision 8

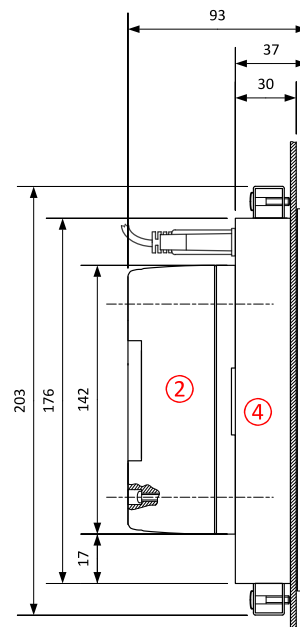
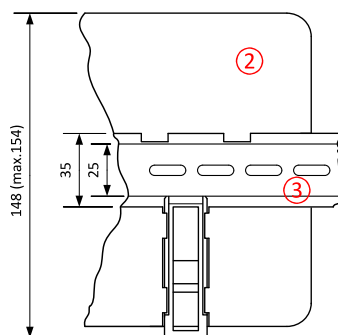
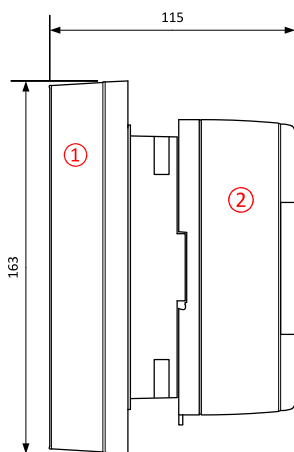

- ① IntelliVision5
- ② IntelliGen<sup>NTC</sup>-BaseBox
- ③ DIN-rail
- ④ IntelliVision 8

**Note:** IntelliGen<sup>NTC</sup> BaseBox can be mounted on a standard DIN rail or, in combination with IntelliVision 5 or IntelliVision 8, it can be door mounted. IntelliVision 5 features mounting rail for direct mounting. Mounting in combination with IntelliVision 8 uses four screws provided in the IntelliGen<sup>NTC</sup> BaseBox package.

## Available Extension modules

Product	Description
Inteli IO8/8	8 Binary inputs, 8 Binary outputs and 2 Analog outputs in a small unit (HW switchable to IO16/0) HW switchable to IO16/0 - 16 Binary inputs packed in a small unit
Inteli AIN8	8 Analog inputs (R, I, V) and 1 pulse/frequency input in a small unit
Inteli AIN8TC	8 Thermocouple Analog inputs in a small unit
Inteli AIO9/1	9 Analog inputs (4x DC, 4x thermocouples, 1x R) in a small unit
IS-AIN8	8 Analog inputs packed in a rugged metal unit
IGS-PTM	8 Binary inputs, 8 Binary outputs, 4 Analog inputs and 1 Analog output in a unit
IGL-RA15	15 Binary LED output (3 colors) packed in a rugged metal unit
I-AOUT8	8 Analog outputs packed in a rugged metal unit
I-LB+	Direct connection (PC) to all controllers on CAN2 or RS485
IB-NT	Communication Module with Cellular/Ethernet Connection

## Related products

Product	Description
InteliVision 5	Color 5.6" display for monitoring and control
InteliVision 8	Color 8" display for advanced monitoring, control & trending, USB capable
InteliVision 12Touch	Color 12" touch display for advanced monitoring, control & trending, USB capable
InteliVision 18Touch	Color 18" touchscreen display designed for complete monitoring and control of multiple controllers or cogeneration installation.
ECON-4	Digital speed governor dedicated for speed control of gas or diesel engines.

## Functions and protections

The product fully supports functions and protections as defined by ANSI (American National Standards Institute). Examples are bellow. Other functions can be found in the IGS-NT Reference guide.

Support of functions and protections as defined by ANSI (American National Standards Institute):

Description	ANSI code	Description	ANSI code
Master unit	1	Voltage unbalance	47
Stopping device	5	Incomplete sequence relay	48
Multi-function device	11	Overcurrent	50/50TD
Overspeed	12	Earth fault	50G
Underspeed	14	Overcurrent IDMT	51
Starting-to-running transition contractor	19	AC circuit breaker	52
Synchronizing-check	25	Overvoltage	59
Thermal relay	26	Pressure switch	63
Undervoltage	27	Liquid level switch	71
Annunciator	30	Alarm relay**	74
Overload(real power)	32P	Reclosing relay	79
Reverse power	32R	Overfrequency	81O
Master sequence device	34	Underfrequency	81U
Excitation loss	40	ROCOF	81R
Unit sequence starting *	44	Auto selective control/transfer	83
Current unbalance	46		

\*MINT

\*\*Extension module IGL-RA15 required



### Greenpower AB

Helsingborgsvägen Varalöv  
262 96 Ängelholm  
Tel: 0431 222 40  
Fax: 0431 222 70  
E mail: info@greenpower.se  
web:www.greenpower.se